

# Spike Island

# Open

Artists' studios

Activities

Exhibitions

Tours

Food & drink

Saturday 3 May

Sunday 4 May

Monday 5 May

11am–5pm

Free entrance

2014

# Open 2014

# Welcome

## Saturday 3 May

11am–5pm	Children's Films, Brunel Square, ss Great Britain, Harbourside BS1
12pm	Spike Design Tour, meet at reception
1–3pm	Workshop: Artist postcards
1pm	Speakers' Corner: Bristol Biennale
2pm	Speakers' Corner: Invisible Dust, High Water Line Project
2–4pm	Spike Print Studio: Vandercook Press demonstration:
3pm	Speakers' Corner: UWE Degree Show
3.30pm	Spike Design Tour, meet at reception
4pm	Speakers' Corner: Mayfest 2014

## Sunday 4 May

12pm	Speakers' Corner: Platform 14
1pm	Speakers' Corner: Shaun Badham, <i>I'm Staying</i>
2–4pm	Spike Print Studio: Vandercook Press demonstration:
3pm	Speakers' Corner: BSDeathdrive
4pm	Speakers' Corner: Andrew Burgess, <i>Horse Power</i>
6–8pm	<i>The Daydream Is What Reality Is (Others)</i> , Curated by Hannah Still The Woodside Press, 22A Islington Road, Bristol BS3 1QB

## Monday 5 May

12pm	Speakers' Corner: All Day Breakfast
12–3pm	Workshop: The Letterpress Collective
2pm	Speakers' Corner: Greg McLare, <i>Atomkraft</i>
2–4pm	Spike Print Studio: Print for a Pound

The hugely popular annual Open Weekend invites visitors to explore behind the scenes at this former Brooke Bond tea packing factory. Now an international centre for art and design, Spike Island is a vibrant hub of creativity for Bristol and the South West and is home to over 70 artists' studios, a print studio, University of the West of England fine art and curatorial courses, as well as many other creative practitioners including designers, film-makers, animators and photographers.

Over the weekend, visitors will find exhibitions, performances, film screenings, opportunities to make and buy art and explore the artists' studios, where they can see works-in-progress and meet and engage with artists on an informal and enjoyable level.

This year the Open is part of the inaugural Bristol Art Weekender, a four-day programme celebrating art across the city and demonstrating Bristol as one of the most exciting and flourishing centres for art in the UK.

# Spike Island Spaces



## Artists' Studios

Throughout the building  
MAP: 19–45 and 76–111

Spike Island is currently home to over 70 artists at all stages of their careers, working across all media from painting and sculpture to print and digital. Spike Island facilitates a creative environment of peer support and collaboration as well as quiet, affordable and accessible places for artists to develop their work.

## Associates Space MAP: W

Spike Associates is a membership network of artists, writers, curators, designers and other creative practitioners. Built on a culture of collaboration and experimentation, the group offers development of individual practices by facilitating new connections, hosting critical discussions and supporting ambitious projects. *Watch a screening of short films by Associates and Studio Holders in the Residency Studio. Point R on the map.*

## Spike Design MAP: G

Spike Design is a co-working space for creative microbusinesses, including graphic, product, digital and interactive designers as well as journalists, illustrators, film-makers and photographers. *Find out more by taking a tour on Saturday at 12pm or 3.30pm or watch a film about our tenants at point F on the map.*



## Situations

Producers of the Bristol Art Weekender, Situations commission and produce both temporary and long-term public artworks, collective programmes and festival events in the South West of England and internationally, as well as acting as a connector to bring people and partners together. Look out for their 'ambassadors' who can tell you about the full programme of Weekender events.

## Spike Print Studio MAP: U

Spike Print Studio is the largest open-access print studio in the South West and a not-for-profit membership organisation. The Studio provides a creative environment for artists as well as offering an educational programme of courses, workshops and masterclasses. *See page 11.*

## WORKS|PROJECTS MAP: K

WORKS|PROJECTS is Bristol's critically acclaimed commercial art gallery. The gallery represents a distinctive stable of British artists including internationally renowned names such as Andy Holden, Heather and Ivan Morison and Richard Woods and works to foster and promote the best artistic talent emerging from the city nationally and internationally.

## UWE Fine Art Studios MAP: H

Around 250 students of the University of the West of England BA and MA Fine Arts and MA curatorial courses work from studios in a 10,000 sq ft unit within Spike Island.

# Exhibitions and Projects

Open all weekend

Andy Holden *MIIMS* (2013)  
Photograph courtesy Zabłudowicz Collection



**Andy Holden** MAP: I

*Maximum Irony! Maximum Sincerity 1999–2003: Towards a Unified theory of MIIMS*  
Spike Island Gallery

This large scale installation incorporating video, music, painting, drawing, sculpture and text is based on the act of recreating and re-imagining an artistic movement Holden founded with four friends before training to be an artist. *MIIMS* was an attempt to create work that is both ironic and sincere.

**Richard Woods** MAP: K

*Bad Brickwork*  
WORKS|PROJECTS

Richard Woods has built an international reputation for his signature architectural transformations. For his third exhibition at WORKS|PROJECTS, Woods fills the gallery with *Bad Brickwork* — beautifully simple new sculptures that resemble cartoon bricks contorting across the gallery in joyous celebration of the most mundane of building materials.  
[www.worksprojects.co.uk](http://www.worksprojects.co.uk)

*To the Edge* MAP: Y

**Spike Print Studio**

An exhibition exploring the challenges of hand printing whether through scale or technique. Works selected by Alice Motard, Spike Island Curator and Jack Gibbon, Director of Antlers Gallery.

**Artists' Studios**

**Throughout the building**  
19–45 and 76–111

Explore the studios of over 70 practicing artists as they open up their spaces and share their work, ideas and inspirations.

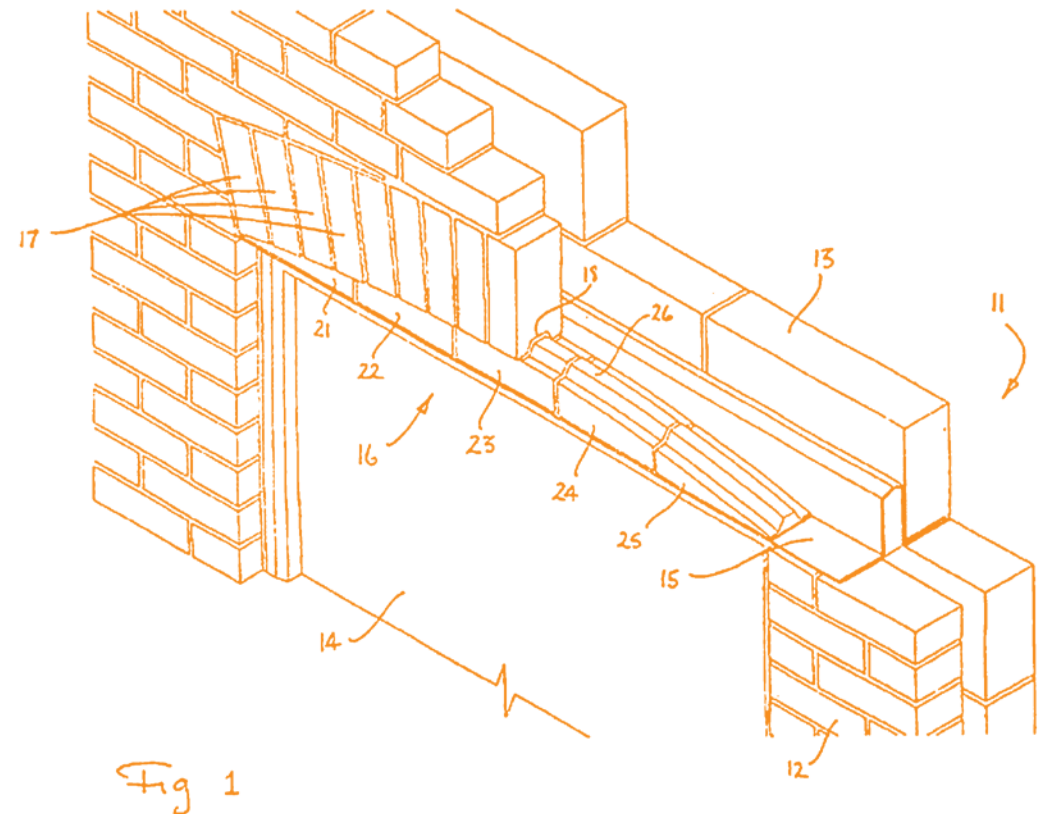

Richard Woods *Bad Brickwork* (2014)  
Courtesy the artist and WORKS|PROJECTS

## Exhibitions and Projects

Aaron McPeake Singing Bowl (2011)



### *Horse Anatomy* MAP: H

#### UWE Fine Art Studios

UWE Fine Arts students present *Horse Anatomy*, an exhibition illuminating the belief systems and ambiguous power relations that contribute to an art body. Three project spaces will be transformed into 'The Head', 'The Heart', and 'The Gut', alluding to particular social, cultural or ideological viewpoints. *Riders*, a café-bar inspired by Jilly Cooper novels will serve cocktails, tea and cake throughout the weekend. *Please note: this part of the Spike Open will close at 3.30pm on Monday.*

### Test Space Open 2014 MAP: V

Test Space is a project space run and curated by Spike Island Studio Holders showing finished work and trialling works in progress. During the Open Weekend Test Space presents a specially curated exhibition resulting from an international call out for work. This year the selection panel comprises Marie-Anne McQuay (curator), Edwina Ashton (artist) and Ruth Claxton (artist).

### Aaron McPeake MAP: L

#### *Singing Bowls*

2014 Shape Residency artist Aaron McPeake returns to Spike Island to present *Singing Bowls* (2010 – ongoing). Visitors are invited to look, touch and listen to the beautiful bronze bowls, creating sounds that resonates throughout the studios.

### Spike Island Timeline MAP: E

Get an overview of what artists, designers, staff and other members of the Spike community have achieved over the last year.

### Associates Space MAP: W

#### *Kittens in a Basket*

Edwina Ashton's kittens are running a photo studio. Visitors are invited to enter the kitten studio where they will be petted and prepared to have their photo taken for outrageous prices. But watch out, these kittens can get angry.

### James Parkinson MAP: M

#### *Light, Medium, Dark, Privacy*

James Parkinson's work explores unpredictable relationships that exist between fragments of visual surfaces and forms, creating objects that trouble the space between painting as image and painting as an almost sculptural object. By installing colour tinted film onto the Spike Café windows, Parkinson asks questions of where surface begins and ends, drawing attention to the issue of what constitutes work and image within a functional environment, and how that environment is complicit in the reading of the work.

### BSDeathdrive MAP: O

By Sam Francis and Emma Lilwall. *BSDeathdrive* is an anonymous offline file-sharing network creating an interactive art distribution activity between artist and public that maps the creativity of the city. 15 Deathdrives (USB sticks) are installed in public locations and art organisations across Bristol. Accessed via a laptop (or mobile phone connector which can be borrowed from selected venues) you can drop, share and collect files and artwork. Each Deathdrive has a read-me file, map of locations and collectable posters. See a showcase of the files found on the Deathdrives in The Dispatch Office (MAP: N).

Deathdrives are installed at key Art Weekender venues including Spike Island. For more info visit: [@bsdeathdrive / #bsdeathdrive](http://www.bsdeathdrive.tumblr.com)

### *Waking up a Shape*

#### The Woodside Press

22A Islington Road, Bristol BS3 1QB  
Saturday 3 May, Sunday 4 May and  
Monday 5 May, 11am–5pm

Bristol-based artists and Spike Associates Edwina Ashton, Anna Clawson & Nicole Ward, Bryony Gillard, Sebastian Jefford, James Parkinson and Hannah Still are joined by Glasgow-based Lauren Gault & Lauren Printy Currie in an exhibition that plays with language to explore the nature of artistic associations. Taking over the former Woodside Press building, the four-day exhibition will feature new works, alongside performances by participating artists on Friday afternoon and Sunday evening.

#### Preview and Performances

Friday 2 May, 3–6pm

Join the artists for an afternoon preview of *Waking up a Shape*. Bryony Gillard will stage a one-off improvised performance using sound, text and action.

#### *Axolotl Milk Bar*

Edwina Ashton and her band of costumed creatures will be serving refreshments at the this pop-up milk bar.

*The Daydream Is What Reality Is (Others)*  
Sunday 4 May, 6–8pm

Hannah Still curates an evening programme of screenings and performances as part of the exhibition. Taking inspiration from the fiction of Brazilian writer Clarice Lispector. Still presents one of her own video/ spoken word pieces as a starting point from which to connect with other works relating to ideas of subjectivity and daydreaming.

# Activities

## Children's Films by Gareth Moore

**Vintage Mobile Cinema, Brunel Square,  
ss Great Britain, Harbourside BS1 6TY  
Saturday 3 May, 11am–5pm**

Screened in a 1960s cinema-bus, this film programme created by Gareth Moore and aimed exclusively at children offers a dedicated cinematic experience for 5–12 year olds. Children are invited to immerse themselves in the world of film with seven 16mm shorts by international contemporary artists: Ulla von Brandenburg, Keren Cytter, Geoffrey Farmer, Julia Fereyr, Harrell Fletcher, Mike Marshall and Sylvain Saily. Duration 25 minutes. No adults allowed unless accompanied by a child.

## Speakers' Corner **MAP: X**

**Saturday 3 May–Monday 5 May  
On the hour from 12–4pm**

Ideas, stories, opinions and theories galore! These short (1 minute) talks by members of the Spike community and special guests will cover a wide range of subjects and are sure to provoke, amuse and entertain. For a schedule of speakers, see Page 2.

Letterpress Collective



## Short Film Screening **MAP: R**

A special programme of moving image work by Spike Island Studio Holders and Associates, selected by artist Cara Tolmie, Lux Head of Programme Gil Leung and Spike Film and Video Producer Ali Roche. View in the Residency Studio or watch online at [www.spikeisland.org.uk/open2014shorts](http://www.spikeisland.org.uk/open2014shorts)

## Letterpress Workshop **MAP: S**

**Monday 5 May, 12–3pm**

The Letterpress Collective lead a drop-in workshop where you can try your hand at printing on the Adana 8x5" vertical platen press. The Letterpress Collective was set up as a not-for-profit Community Interest Company in 2013 after the last commercial letterpress company closed after over 500 years of printing in the city. Its aim is to preserve and use the presses and type, to run compositor and print workshops and produce beautiful and effective print.

## Spike Print Studio Fundraisers **MAP: U**

All proceeds go towards improving equipment for the learning programme and the studio.

**WIN:WIN — Lucky Dip  
Friday 2 May–Monday 5 May  
£5 per ticket**

This lucky dip guarantees you an original, limited edition unframed print generously donated by Spike Print Studio artists.



Spike Print Studio

## Postcard Workshop **MAP: S**

**Saturday 3 May, 12–3pm**

Record your response to the Spike Island Open by making your own artist postcard. Participants can draw, collage, or print their ideas using different papers, images and objects, as well as rubber stamps or simple lino cuts to create a miniature work of art. Led by Rebecca Wilson.

**Vandercook Press Demonstration  
and Printing  
Saturday 3 May and Sunday 4 May  
2–4pm**

Spike Print Studio artists will be demonstrating the unique Vandercook Press as they print a limited edition poster designed especially for the Spike Island Open by Georgina Hounsome and Alex Higlett. 150 posters will have been printed in advance and be available for sale. The remaining 100 posters will be printed during the Open Weekend and can be bought hot off the press.

**Print for a pound  
Monday 2–4pm, £1**

This extremely popular activity lead by Jo Hounsome allows you to create and walk away with your very own print.

## Spike Design Tour **MAP: G**

**Saturday 3 May, 12pm and 3.30pm  
Meet at reception**

Take a tour around this dynamic co-working space and learn about the creative businesses that are based here. Led by Jane Macfarlane, Spike Design Administrator. You can also watch a film about their work. (MAP: F).

# Ground floor

A	Stairs	19	Luke Jerram	42	Steve Joyce
B	Lift	19	Louisa Fairclough	43	Ben Rowe
C	Toilets	19	Kit Poulson	44	Cathy Lewis
*	Information point	21	Philippa Lawrence	45	Colin Higginson
		22	Beth Carter		
D	Spike Café	24	John De Mearns		
E	Spike Island Timeline	25	Seamus Staunton		
G	Spike Design	26	Robert Foster		
H	UWE Fine Art studios	26	Richard Broomhall		
I	Andy Holden	26	Helen Grant		
	<i>Maximum Irony!</i>	27	Rod MacIachlan		
	<i>Maximum Sincerity 1999-2003:</i>	29	Gina Lundy & Julie Mccalden		
	<i>Towards a Unified Theory of MII/MS</i>	28	John Wood and Paul Harrison		
		31	Kevin Wright		
J	La Bonne Crêpe	32	Annabelle Craven Jones		
K	WORKS PROJECTS	33	Victoria Coombes		
L	Aaron McPeake	34	Anton Goldenstein		
	<i>Singing Bowls</i>	35	Michael Hayter		
M	James Parkinson	36	Anna Clawson and Nicole Ward		
	<i>Light, Medium, Dark, Privacy</i>	37	Rod Harris		
N	BS Deathdrive exhibition	37	Valda Jackson		
O	BS Deathdrive	38	Kate Parsons		
P	Plenderleith Scantlebury	39	Marcus Jeffries		
Q	Hickory Pig	40	Patrick Haines		
	Claud the Butler	41	Richard Hames		

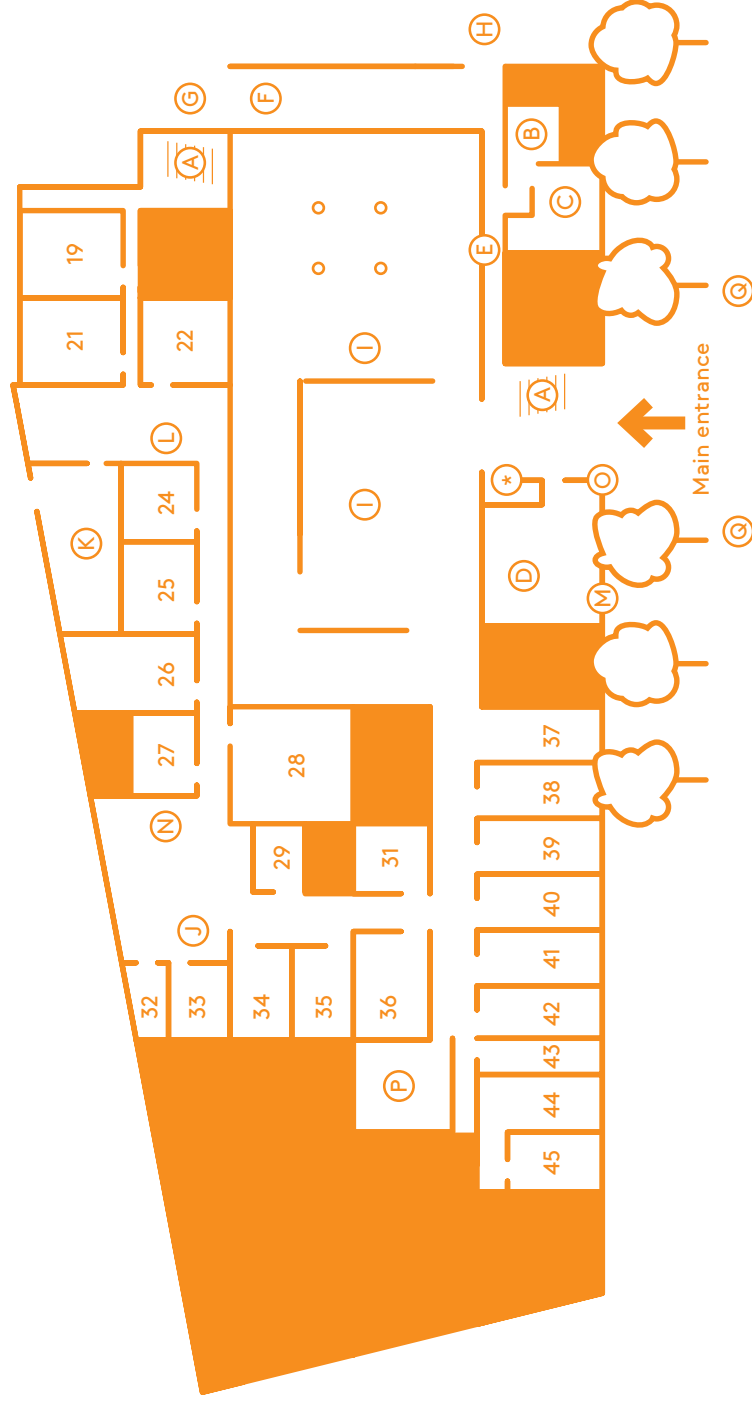





# Cafés

## La Bonne Crêpe MAP: J

La Bonne Crêpe is traditional and homemade creperie serving delicious crêpes and galettes (savory crêpes, gluten/wheat and dairy free) using local, fair-trade and organic products.

## Spike Café MAP: D

Our in-house eatery offers a wide range of delicious, freshly prepared meals and snacks, hot drinks, juices, wine and beer.

## Riders MAP: H

UWE's pop-up café-bar inspired by Jilly Cooper's novel serves tea and cake and cocktails throughout the weekend. Open Friday, 6–9pm, Saturday and Sunday, 11am–5pm. Closes at 3.30pm on Monday 5 May.

## Hickory Pig MAP: Q

Authentic low 'n' slow BBQ. Everything is homemade, from scratch. #digthepig

## Claud the Butler MAP: Q

'Claud the Butler' will be on hand to serve up finest Mozzo coffee and delectable home-made cakes from their lovingly restored vintage vans.

## Little Moo ROAMING TRICYCLE

Vee Double Moo's ice cream trike, serves luxury handmade ice cream from Chew Moo's all the way from Dundry.

## Ferry Information

Bristol Ferry Company operates between Arnolfini and the SS Great Britain, just a short walk from Spike Island. Tickets cost £1.50, or £2.50 return. On Friday night the service will run from 7.30–9pm.

# Support Us

Spike Island is a registered charity that works to support emerging artists and creative practitioners regionally, nationally and internationally. We need your help to do this, and to enable us to continue creating our year-round

programme of exhibitions and events, many of which are free, including the Open Weekend. Please consider helping us by making a donation at reception. Thank you.